

Technical Data Sheet (TDS)

HS Translucent Gradient Multi-Color PETG

ERYONE High-Speed Translucent Gradient PETG Filament combines two elegantly blended colors in a smooth gradient, delivering exceptional optical clarity ideal for aesthetic lighting applications like lampshades that project captivating light patterns. Engineered for rapid production, its superior flow characteristics support print speeds up to 600 mm/s while maintaining flawless surfaces with consistent gloss. This material retains PETG's core advantages: water resistance, chemical resistance, high toughness, and effortless printability – making it perfect for functional components, decorative homeware, and specialized projects in medical/educational fields.

Part I: Suggests Printing Parameters

Parameter	Set up
Nozzle temperature	240-280 °C
Bed temperature	75-80°C
Bed material	glass, PEI, spring steel plate
Bottom printing temperature	240-280 °C
Sealed printing	supports open printing, and the sealing effect is better if it is sealed
Printing speed	30-600mm/s
Drying conditions	60-65°C, 6-8h

Part II: Physical Properties of Materials

Property	Testing Method	Unit	Typical Value
Density(g/cm ³ at 21.5 ° C)	ASTM D792 (ISO 1183, GB/T 1033)	g/cm ³	1.28
Vicat Softening Temperature(° C)	ASTM D1525 (ISO 306 GB/T 1633)	°C	70
Heat distortion temperature(° C)	ASTM D648 0.45MPa	°C	69
Melt Index(g/10 min)	220 ° C, 10kg 240 ° C, 2.16 kg	g/10min	28.2±2.7

Part III: Mechanical Properties of Printed Samples

Property	Test conditions	Test standards	unit	Typical Value
Tensile strength X-Y	50mm/min	GB/T 1040.4	MPa	50.1
Elastic modulus X-Y	50mm/min	GB/T 1040.1-2006	MPa	1332.1
Elongation at break X-Y	50mm/min	GB/T 1040.4	%	4.1
Tensile strength X-Z	50mm/min	GB/T 1843	MPa	21.7±2
Elastic modulus X-Z	50mm/min	GB/T 1040.1-2006	MPa	1034.2
Elongation at break X-Z	50mm/min	GB/T 1040.2	%	2.7
Bending strength	2mm/min	GB/T 9341	MPa	66.1
Bending modulus	2mm/min	GB/T 9341	MPa	1742.3
Charpy Impact strenght	2.75J	GB/T 1043.1-2008	kJ/m2	1.25

Note: All splines are printed under the following conditions: printing temperature=240 ° C, printing speed=100mm/s, base plate 80 ° C, filling=100%, nozzle diameter=0.4mm

TENSILE TESTING SPECIMEN

ISO 527,GB/T 1040

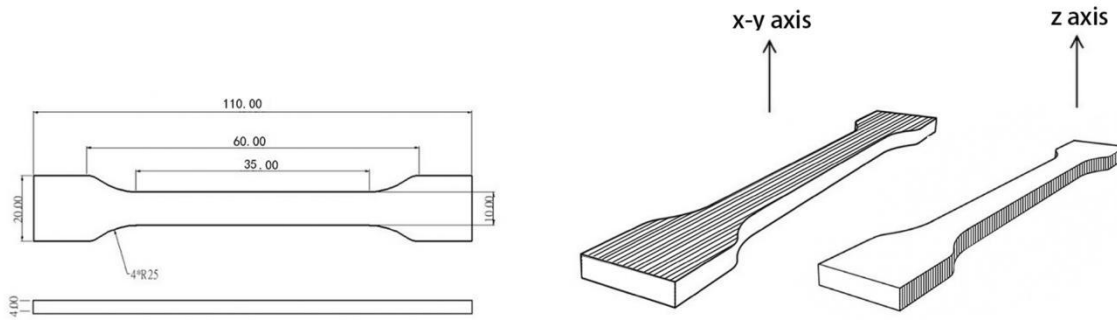

FLEXURAL TESTING SPECIMEN

ISO 178,GB/T 9341

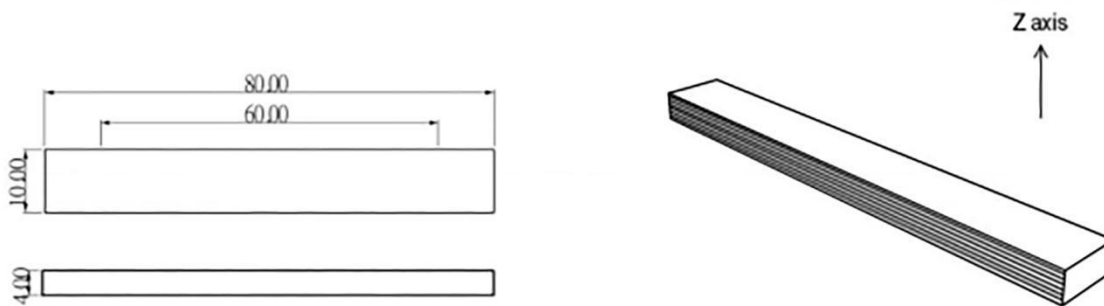

IMPACT TESTING SPECIMEN

ISO 179,GB/T 1043

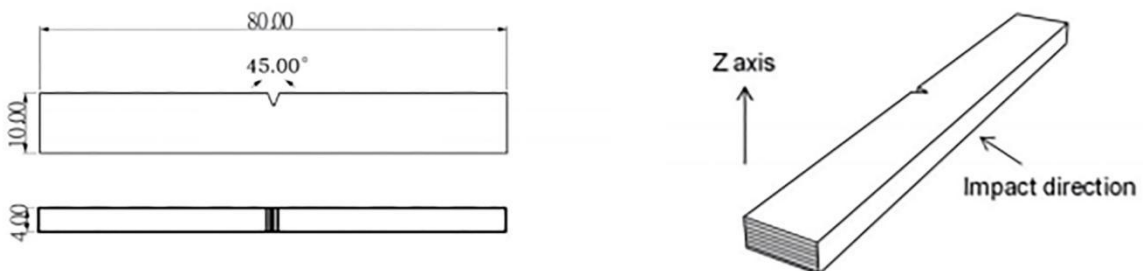

Disclaimers

The values given in this data table are for reference and comparison only. They should not be used for design specifications or quality control. The actual value may vary depending on the printing conditions. The final performance of printed components depends not only on the material, but also on the component design, environmental conditions, printing conditions, and so on. Product specifications are subject to change without prior notice.