

# Technical Data Sheet (TDS)

## Galaxy PLA

Eryone Galaxy PLA filament is a material with a sparkling surface, offering a cool and fresh appearance. It is perfect for everyday crafts and model toys, providing high playability and a shimmering effect. This product is developed based on PLA material, making the forming process very simple and convenient.

### Part I: Suggests Printing Parameters

Parameter	Set up
Nozzle temperature	190°C-220°C
Bed temperature	55-70°C
Bed material	glass, PEI, spring steel plate
Bottom printing temperature	190°C-220°C
Sealed printing	Open Printing/closed printing
Printing speed	30-60mm/s
Drying conditions	50°C-60°C, 6H

### Part II: Physical Properties of Materials

Property	Testing Method	Unit	Typical Value
Density(g/cm <sup>3</sup> at 21.5 ° C)	ASTM D792 (ISO 1183, GB/T 1033)	g/cm <sup>3</sup>	1.23
Vicat Softening Temperature(° C)	ASTM D1525 (ISO 306 GB/T 1633)	°C	54
Glass transition temperature (° C)	DSC, 10 ° C/min	°C	63
Heat distortion temperature(° C)	ASTM D648 0.45MPa	°C	53
Melt Index(g/10 min)	220 ° C, 10kg 240 ° C, 2.16 kg	g/10min	6

### Part III: Mechanical Properties of Printed Samples

Property	Test conditions	Test standards	unit	Typical Value
Tensile strength X-Y	50mm/min	GB/T 1040.4	MPa	54.2
Elastic modulus X-Y	50mm/min	GB/T 1040.1-2006	MPa	2034.5
Elongation at break X-Y	50mm/min	GB/T 1040.4	%	2.1
Tensile strength X-Z	50mm/min	GB/T 1843	MPa	27.8
Elastic modulus X-Z	50mm/min	GB/T 1040.1-2006	MPa	1872.8
Elongation at break X-Z	50mm/min	GB/T 1040.4	%	1.9
Bending strength	2mm/min	GB/T 9341	MPa	78.7
Bending modulus	2mm/min	GB/T 9341	MPa	2568.9
Charpy Impact strenght	2.75J	GB/T 1843	kJ/m2	2.8

Note: All splines are printed under the following conditions: printing temperature=210° C, printing speed=80mm/s, base plate 60 ° C, filling=100%, nozzle diameter=0.4mm

## TENSILE TESTING SPECIMEN

ISO 527,GB/T 1040

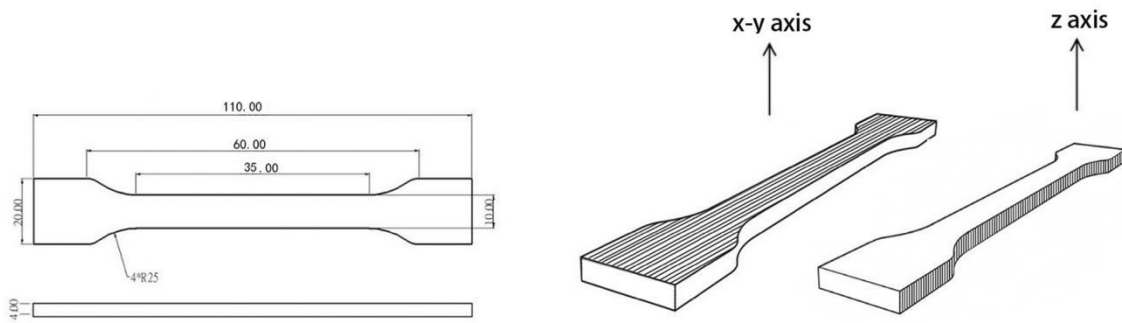

## FLEXURAL TESTING SPECIMEN

ISO 178,GB/T 9341

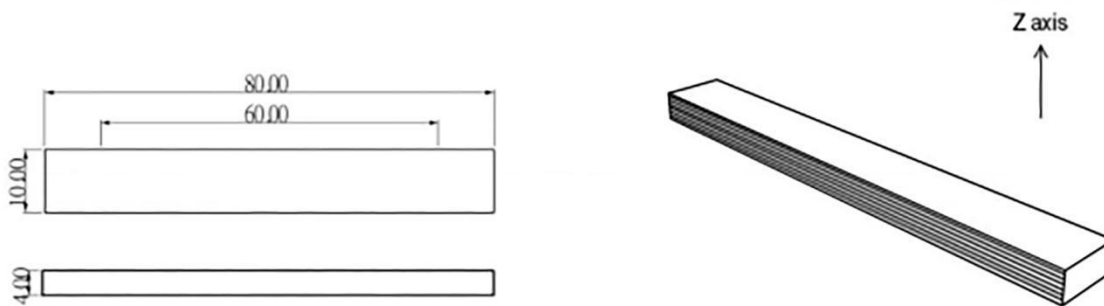

## IMPACT TESTING SPECIMEN

ISO 179,GB/T 1043

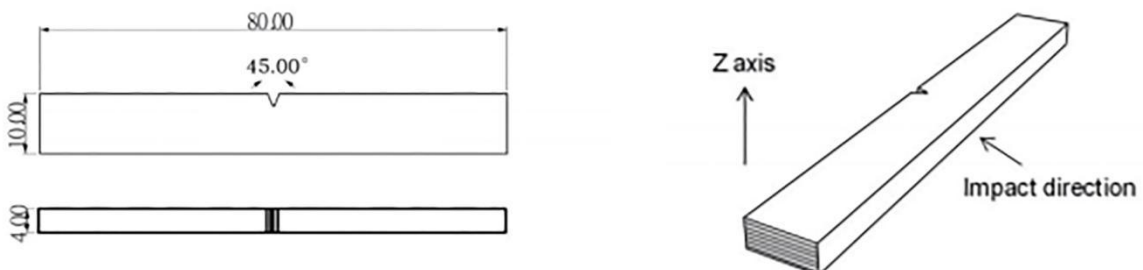

## Disclaimers

The values given in this data table are for reference and comparison only. They should not be used for design specifications or quality control. The actual value may vary depending on the printing conditions. The final performance of printed components depends not only on the material, but also on the component design, environmental conditions, printing conditions, and so on. Product specifications are subject to change without prior notice.